

FRVKOO_M001

14.12.2021

Emergency-stop with 4-pole M12 connector



General Data

Type reference	FRVKOO_M001
Description	Pre-assembled emergency-stop pushbutton with M12 connector
Approvals	CE, cURus, TÜV_Süd, UKCA
Contact type	2 NC
Degree of protection	IP65 / IP67 (in the front); IP65 (on the rear)
Connection type	M12 connector with PUR cable, A coded; wires 0,34mm ² (AWG22)
Contact material	AgNi
Max. storage temperature	-40°C ... 80°C
Max. operating temperature	-25°C ... 70°C
Mechanical life	50,000 switching cycles
Electrical life (rated load)	50,000 switching cycles at rated load
Contact resistance NC	< 100 mOhm, typ. 50 mOhm (25 cm cable, AgNi contact block, new state)
Bouncing time NC	< 10ms
Positive opening contact	acc. to EN60947-5-1, appendix K

Electrical data acc. to IEC/EN 60947-5-1 (VDE 0660 Sect. 200)

	alternate current	direct current
Utilisation category	AC15	DC13
Rated insulation voltage Ui	250 V	250 V
Rated operating voltage Ue	35 V	35 V
Rated operating current Ie	4 A	2 A
Breaking capacity	10Ie	1,1Ie
Continuous thermal current	4 A	4 A

Additional data

Mounting aperture	22.3 mm
Tightening torque (mounting nut)	1.0 ... 1.7 Nm
Release	twist release, left or right



Mounting position	any
Standards	EN 60947-5-1, EN 60947-5-5, EN ISO 13850
Tightening torque (M12-connector)	max. 0.4 Nm
Ld	20% (NC)
B10d [cycles]	250,000
Rated impulse voltage	2.5 kV
Material group	I
Overvoltage category	II
Pollution degree	2
Operating force	approx. 30 N (at 20 mm/min)

Note

O = NC contact
- with switching position indicator

4-pole M12 connector with cable:
- PUR cable with M12 connector straight, black
- wires 0.34 mm² (AWG22)
- integrated stain relief
- length: 25±3 cm
- cable diameter: 4.7 mm
- bending radius moving: 10 x cable diameter
- bending radius fixed: 5 x cable diameter

Pin assignment:
Pin 1 Pin 2 Pin 3 Pin 4 Type
NC (1) NC (1) NC (2) NC (2) 2 NC

Safety instructions / mounting instructions
- the connector must not be connected or disconnected under load
- the single connector pin may be loaded with max. 4 A

Data acc. to UL/IEC 60947-5-5

Rating	30V AC/DC 3A
Torque	1.3 ... 1.9 Nm (head nut)
Enclosure Type	Type 4X (indoor) front face



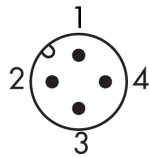
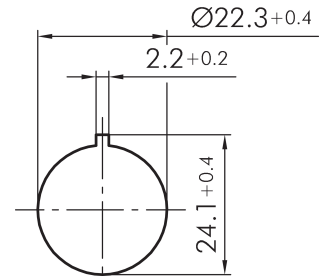
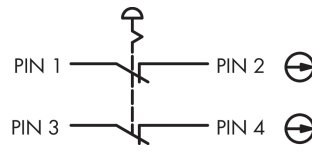
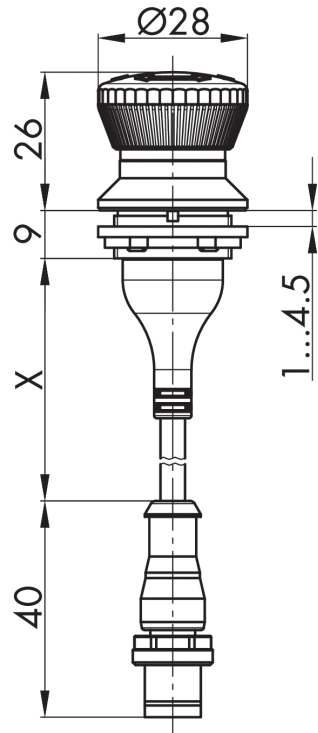

M12

